

# EXPERTS IN MOVEMENT SOLUTIONS



**Accuride**<sup>®</sup>  
*Always Moving Forward*

Over the years Accuride has designed access, positioning, and motion into a diverse range of applications.



## Engineering & Design Resources

Our engineering and technical teams offer a broad range of industry knowledge and experience. From the first glimmer of an idea to the manufacturing line, Accuride has the expertise to see your project through from start to finish.

*Reversible mounting brackets designed to fit square, round, or tapped holes*

**ELECTRONIC ENCLOSURE APPLICATIONS**

*Narrow cross section to maximize space*

*Push slide member to rear to lock screws/pins*

*Tool-less mounting solutions*

Technical callout dimensions:  
 .28" [7.2]  
 1.62" [41.2]  
 .22" [5.7]

## Manufacturing and Plating

Accuride has 77 roll form machines, 9 plating lines, and 2 in-house steel mills. This equipment enables us to control quality and accommodate virtually any design and projects of every size. We excel in metal fabrication and the development of manufacturing efficiencies. As one of the largest zinc electroplaters in the world, over the years, we have developed, improved, and refined plating methods, including specialty formulations designed for extreme environmental conditions.



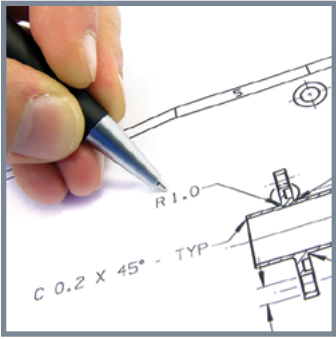

## Product Design and Integration

We study proposed applications to gain a thorough understanding of design requirements. We are adept at developing cost-effective product concepts, whether it is a single component or complete assembly. Accuride is the authority on application integration.



*Under-seat compartment with secured access*

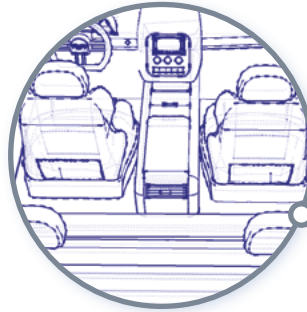

*Rear Compartment Storage*

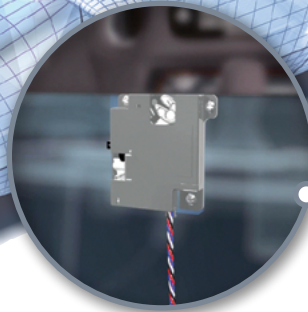
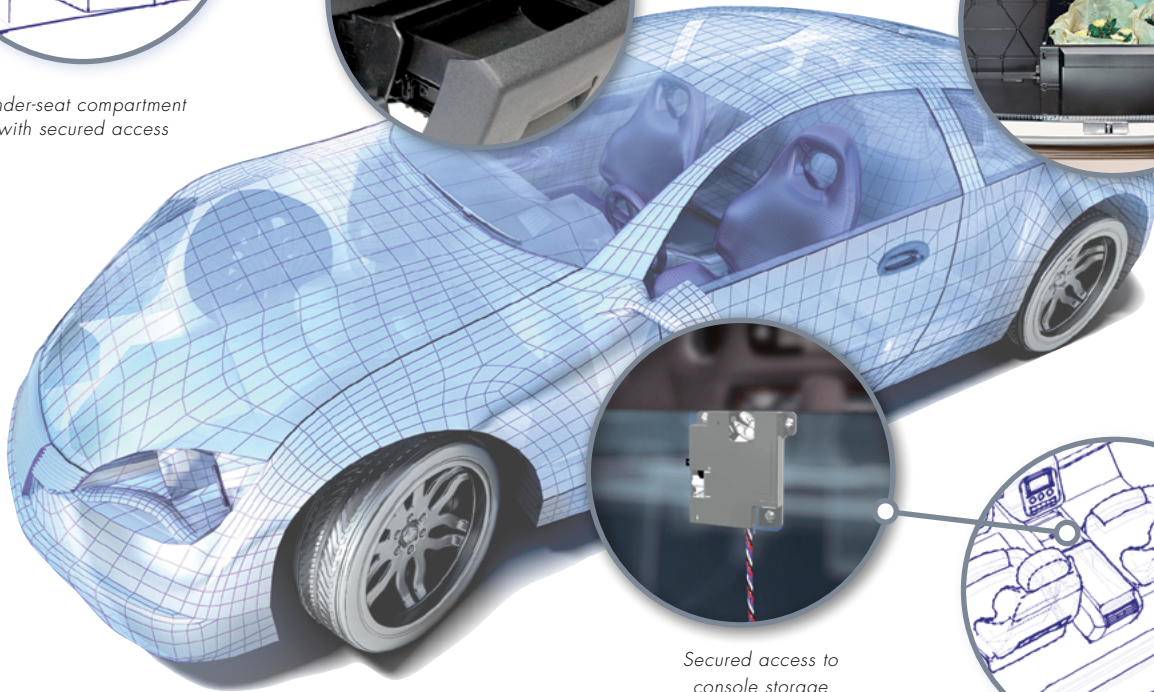

*Secured access to console storage*

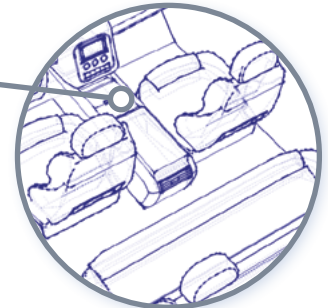

### AUTOMOTIVE STORAGE & ACCESS APPLICATIONS

## Quality and Testing

Accuride production facilities maintain quality management systems certified to ISO 9001:2008 and adhere to the ISO 14001 Environmental Standard. All finishes and slide components are RoHS compliant. With one of largest test labs in the industry, all products are tested to meet or exceed ANSI standards. Additionally, customized testing is conducted for special projects.

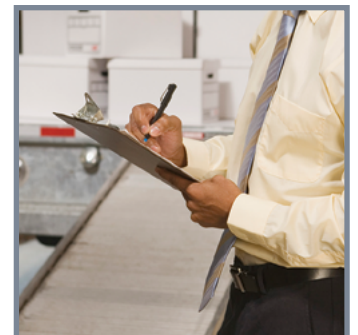

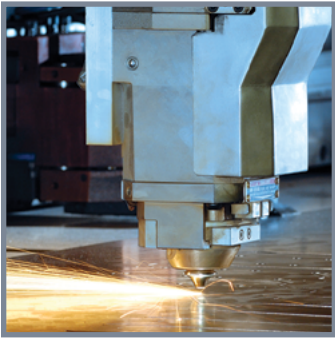

## Tooling and Prototyping

Our North American facilities host one of the largest tooling operations on the continent. We build and maintain the progressive dies and roll forms used for prototypes and final production using methods we have standardized worldwide. Accuride builds prototypes in zinc, aluminum, plastic, and steel, and offers soft tooling solutions to ensure rapid time-to-market.

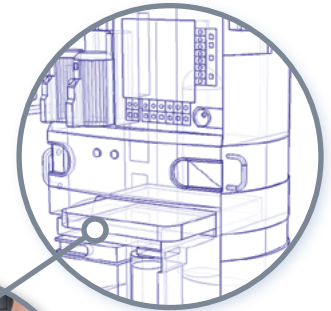

*Electronic locking slides secure supplies or medications*

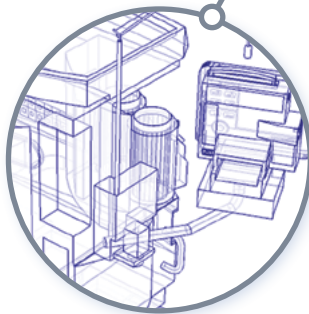
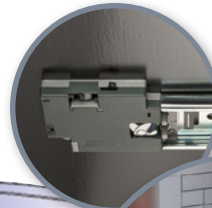

*Our mechanical lift conceal monitors or touch screens*

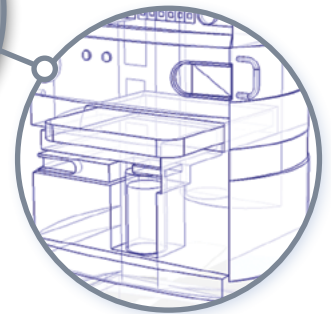
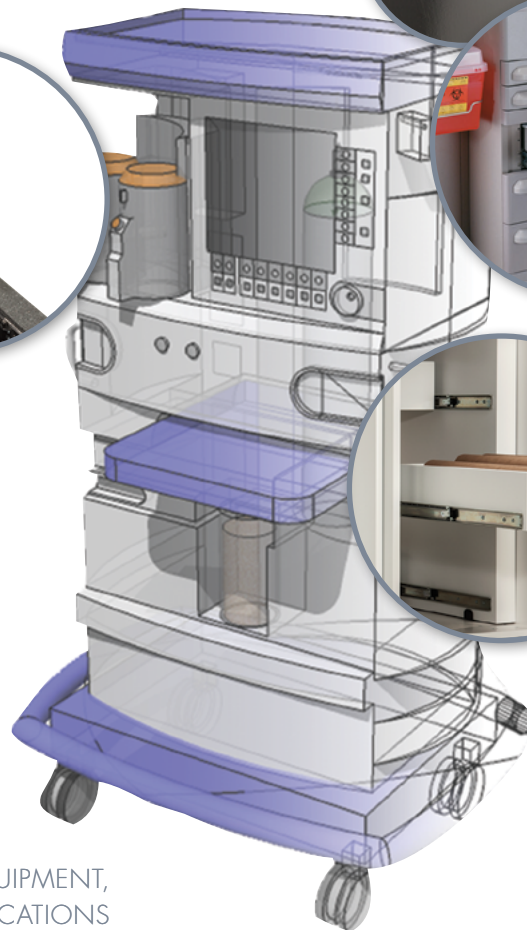

*Slide options include positive hold-out, touch latch release, and 2-way travel*

MEDICAL CARTS, EQUIPMENT,  
AND CASEWORK APPLICATIONS

## Materials, Logistics, and Cost Management

Accuride offers services such as inventory and supply chain management and warehousing. We build long-term partnerships with essential vendors and have back-up sources for all commodities. These measures ensure on-time delivery and the highest quality products at competitive prices.



# Market Applications

Put our imagination and expertise to work for you.



## ELECTRONIC EQUIPMENT & ENCLOSURES

Providing movement, access, and security solutions for server racks, telecommunication storage, and other electronic chassis applications.



## MEDICAL EQUIPMENT

Dispensing and supply carts, diagnostic equipment, secured storage, and other technical and patient care applications.



## INDUSTRIAL EQUIPMENT

Machinery and production line equipment—from a single component to the entire chassis.



## AUTOMOTIVE & MARINE

Positioning, access, security, and movement for armrests, seats, doors, and cargo and equipment storage in consumer, business, and service applications.



## APPLIANCES

Consumer and commercial appliances: freezers, refrigerators, ovens, and range hoods.



## AEROSPACE & MILITARY

Precision and reliability are key factors for these industry applications that range from basic to mission-critical.



## FURNITURE & CABINETS

Movement and security solutions for fine furniture, cabinetry, and architectural casework in residential, commercial, and institutional applications.



Accuride was the first U.S. based slide manufacturer awarded ISO 9000 certification. Today, all production facilities have quality management systems registered to ISO 9001:2008.



All slide finishes and components comply with the Restriction of Hazardous Substances (RoHS) Directive.

## Your Global Partner

Our extensive capabilities establish Accuride as a worldwide presence who can collaborate with companies in any industry, anywhere.

### North America International Headquarters

12311 Shoemaker Avenue  
Santa Fe Springs, CA 90670  
(562) 903-0200 Telephone  
(562) 903-0208 Fax  
[www.accuride.com](http://www.accuride.com)

### Europe

Accuride International Ltd.  
Liliput Road  
Brackmills Industrial Estate  
Northampton, NN4 7AS  
United Kingdom  
+44 (0) 1604 761111 Telephone  
+44 (0) 1604 767190 Fax  
[www.accuride-europe.com](http://www.accuride-europe.com)  
E-mail: [saleseurope@accuride.com](mailto:saleseurope@accuride.com)

### Asia

Accuride Japan Company Ltd.  
44 Minami-asaji Iwata Yawata-shi  
Kyoto, Japan  
+81 (75) 983-7500 Telephone  
+81 (75) 983-9500 Fax  
[www.accuride.co.jp](http://www.accuride.co.jp)  
E-mail: [info@accuride.co.jp](mailto:info@accuride.co.jp)

### North America Manufacturing

Accuride International, S.A. de C.V.  
Calle Circuito Norte No. 6  
Parque Industrial Nelson  
Mexicali, B.C., C.P. 21395 México

### Europe

Accuride International GmbH  
Werner-Von Siemens-Strasse 16-18  
65582 Diez/Lahn  
Germany  
+49 (0) 6432 608 - 0 Telephone  
+49 (0) 6432 608 - 320 Fax  
[www.accuride-europe.com](http://www.accuride-europe.com)  
E-mail: [saleseurope@accuride.com](mailto:saleseurope@accuride.com)

### Asia

Accuride International Suzhou Co. LTD  
No. 178, Suhong East Road  
Suzhou Industrial Park  
Jiangsu Province, China 215026  
+86-512-62731200 Telephone  
+86-512-62833993 Fax  
[www.accuride.com.cn](http://www.accuride.com.cn)  
E-mail: [saleschina@accuride.com](mailto:saleschina@accuride.com)

**Accuride**<sup>®</sup>  
*Always Moving Forward*

[www.accuride.com](http://www.accuride.com)

