



Structural
Acoustical
Roof Deck

FLECTUM[®]

Armstrong[®]
BUILDING SOLUTIONS

TECTUM®

Structural Acoustical Roof Deck

- ▶ Excellent noise absorption – NRC up to 0.80 helps meet ANSI S12.60 acoustical criteria
- ▶ Durable for heavy-use interiors
- ▶ Sustainable – contributes to LEED® V4
- ▶ Faster and easier to install – compatible with many roofing materials
- ▶ Class A fire rating
- ▶ Proven economical roof decking solution for over 65 years
- ▶ Miami Dade NOA Approved #18-0619.03 (Tectum IIIW)

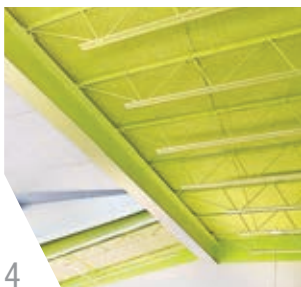

4

PRODUCT OVERVIEW,
SUSTAINABILITY &
ACOUSTICS



7

DESIGN DATA



10

SELECTION CRITERIA



11

TECTUM® I
ROOF DECK PANELS



14

TECTUM COMPOSITE
ROOF DECK PANELS



19

CODE COMPLIANCE

Tectum ▶
Roof Deck panels
Northland Workforce
Training Center, Buffalo, NY



TECTUM® STRUCTURAL ACOUSTICAL ROOF DECK SOLUTIONS

For over 65 years, Tectum® Building Solutions has provided reliable, sustainable, acoustical roof decking solutions to meet the commercial construction industry's needs. Tectum® Roof Deck solutions are available in a wide variety of system configurations to match the unique needs of your building design.

Tectum Roof Decks are manufactured in Newark, Ohio, and composed of rapidly renewable and FSC® certified aspen wood fiber that is bonded with an exclusive, inorganic hydraulic cement for maximum durability and performance.

▼ Tectum E Roof Deck in custom color
Duran Elementary School, Albuquerque, NM



SUSTAINABILITY & LEED® V4

Tectum® Roof Deck solutions meet the most stringent industry sustainability criteria (EPD, HPD, Declare®), and contribute favorably to LEED® V4, Living Building Challenge®, and WELL Building Standard™.

For complete details, visit armstrongbuildingsolutions.com/tectum



▲ Tectum® III Roof Deck in White
Glick Field House, University of Michigan
Ann Arbor, MI

TECTUM® I ROOF DECK LEED V4 OVERVIEW

Theme	Credit	LEED Credit	Points
Energy Credits	EA Prerequisite	Minimum Energy Performance	Required
	EA Credit	Optimize Energy Performance	Dependent on Reduction
Recycling Program	MR Prerequisite MR Credit	Construction & Demolition Waste Management Planning Now a Prerequisite – ID at least 5 materials	MRp Required MRc Up to 2 pts
		Construction & Demolition Waste Management	
Regional Materials	MR Credit	Regional Materials (Extracted, manufactured, and purchased within 100 miles)	200% base contributing cost
Life Cycle Impacts & Environmental Product Declarations	MR Credit	Building Life Cycle Reduction Interiors Life Cycle Impact Reduction	BD&C – 1-2 ID&C – 1-2
Life Cycle Impacts & Environmental Product Declarations	MR Credit	Building Disclosure and Optimization – Environmental Product Declaration	BD&C – 1-2 ID&C – 1-2
Corporate Sustainability and Raw Material Sourcing	MR Credit	Building Disclosure and Optimization – Sourcing of Raw Materials	BD&C – 1-2 ID&C – 1-2
Material Ingredient Disclosure	MR Credit	Building Disclosure and Optimization – Material Ingredients	BD&C – 1-2 ID&C – 1-2
Acoustics	EQc	Acoustic Performance (now all Rating Systems)	BD&C – 2 ID&C – 2

TECTUM® COMPOSITE ROOF DECK LEED V4 OVERVIEW

Theme	Credit	LEED Credit	Points
Energy Credits	EA Prerequisite	Minimum Energy Performance	Required
	EA Credit	Optimize Energy Performance	Dependent on Reduction
Recycling Program	MR Prerequisite MR Credit	Construction & Demolition Waste Management Planning Now a Prerequisite – ID at least 5 materials	MRp Required MRc Up to 2 pts
		Construction & Demolition Waste Management	
Regional Materials	MR Credit	Regional Materials (Extracted, manufactured, and purchased within 100 miles)	200% base contributing cost
Life Cycle Impacts & Environmental Product Declarations	N/A	N/A	N/A
Life Cycle Impacts & Environmental Product Declarations	N/A	N/A	N/A
Corporate Sustainability and Raw Material Sourcing	MR Credit	Building Disclosure and Optimization – Sourcing of Raw Materials	BD&C – 1 ID&C – 1
Material Ingredient Disclosure	N/A	N/A	N/A
Acoustics	EQc	Acoustic Performance (now all Rating Systems)	BD&C – 2 ID&C – 2

EXCEPTIONAL ACOUSTICAL PERFORMANCE

- Tectum® Roof Deck panels provide noise absorption up to NRC 0.80 eliminating the need for additional acoustical materials.
- Tectum panels help to meet ANSI S12.60 Acoustical Performance Criteria, Design Requirements, and Guidelines for Schools.

▼ Tectum E Roof Deck in custom colors
Duran Elementary School, Albuquerque, NM



TECTUM ACOUSTICAL VALUES

Panel Thickness	Tectum I	Tectum® III, Tectum IIIW	Tectum® E (with 2" EPS Insulation)	Tectum® V (with 6" GPS Insulation)
1-1/2"	0.55	–	–	0.60
2"	0.60	–	0.70	–
2-1/2"	0.65	–	0.75	–
3"	0.80	0.60	0.80	–

TECTUM DESIGN DATA



▲ Tectum E Roof Deck in custom colors Duranes Elementary School, Albuquerque, NM

DESIGN LOAD DATA

All published design loads are based on minimum safety factor of four. For example, 50 psf design load has an ultimate load of 200 psf. Span in inches based on nominal 3" wide structural support members with deflection of L/240 or less.

System	Thickness ¹	Weight (PSF) ¹	24"	30"	36"	38"	40"	42"	44"	48"	50"	52"	54"	60"	66"	72"	84"	96"	108"	120"	132"	144"		
Tectum® I																								
Plank	2"	3.5	130	75	50	45	40	35																
	2-1/2"	4.5	150	120	80	70	60	50	45	35														
	3"	5.3	200	125	102	91	82	74	65	50	45	40	35											
LS Plank	2"	3.8	130	75	75	75	70	64	57	50	45	40	35											
	2-1/2"	4.7	150	120	120	120	114	103	93	77	70	65	60	50	35									
	3"	5.5	200	125	125	125	125	120	115	110	104	96	88	71	58	50								
Tectum® NS																								
Plank	2-1/2"	4.1	200	125	100	90	80	74	65	50														
	3"	5.1	200	195	135	120	110	100	90	75	70	65	60	50										
	3-1/2", 4"	6.1, 6.9	200	195	175	155	140	120	110	100	95	85	70	60	50									
Tectum® III & IIIP²																								
Plank	3-1/2"	4.0	200	180	165	150	135	125	115	95	85	75	70	60	55	50								
	4"	4.1	200	195	175	155	140	120	110	100	95	85	70	60	50	35								
	5"	4.7					200	175	135	125	115	105	85	70	60	50	35							
	6", 7"	4.8, 5.0							200	180	170	160	150	125	105	75	60							
	8", 9", 10"	5.4, 5.8, 6.2											200	165	136	100	75							
Tectum® IIIW																								
Plank	5"	5.0					200	175	135	125	115	105	85	70	60									
	6", 7"	5.2						200	180	170	160	150	125	105										
	8", 9", 10"	5.5											200	165	136									
Tectum® E & E-N																								
Plank	2-3/4"	4.2	200	125	100	90	80	74	65	50														
	3-1/2"	4.2	200	150	135	120	110	100	90	75	70	65	60	50										
	4"	4.3	200	180	165	150	135	125	115	95	85	75	70	60	55	50	35							
	5"	4.4	200	195	175	155	140	120	110	100	95	85	70	65	60	45								
	6", 7"	4.4, 4.5							200	180	170	160	150	125	105	75	60							
	8", 9", 10"	4.6, 4.7, 4.8											200	165	130	100	75							
Tectum® V																								
Plank	9"	6.0																		112	88	72	59	50

For loads greater than 200 lbs., contact Armstrong World Industries TechLine.

¹ Thickness and weight are nominal.

² Contact Armstrong World Industries TechLine when designing high-humidity environments such as pools and ice arenas.

TECTUM Design Data

DIAPHRAGM DESIGN DATA Call for assistance when designing and detailing Tectum® Roof Deck Systems

Type	Panel Size D x W x L	Joist	Span ¹	Fasteners	Field Spacing	Perimeter	Adhesive ²	Grout	ULT/LF	DSN/LF
Tectum® I										
Plank	3 x 31 x 96"	Steel	48"	S-25/2" Washer (w)	3/Joist/Panel	16" O.C.	No T&G + Joist	None	825 1350	275 450
LS	2-1/2 x 31 x 120"	Wood	60"	3-3/4" 14-Gauge Scr/2"w	2/Joist/Panel	10" O.C. sides + ends	T&G + Joist	None	1170	389
	3 x 31 x 144"	Wood	72"	4-1/2" 14-Gauge Scr/2"w	2/Joist/Panel	12" O.C. sides + ends	T&G + Joist	None	860	286
	2 x 31 x 96"	Wood	48"	3-3/4" 14-Gauge Scr/2"w	2/Joist/Panel	12" O.C. sides + ends	T&G + Joist	None	964	321
	3 x 31 x 144" ³	Wood	72"	4-1/2" 14-Gauge Scr/2"w	2/Joist/Panel	12" O.C. sides + ends	T&G + Joist	None	1631	542
Tile	2 x 23-1/2 x 143"	Steel	72"	112 Ts/112 x Ts	24" O.C.	112 Ts	No	4 Sides	925	313
	2 x 31-1/2 x 95"	Steel	96"	168 Ts/112 x Ts	32" O.C.	158 Ts	No	4 Sides	575	200
	2 x 31-1/2 x 95"	Steel	96"	000-5-14-2+S-25/2"w	2/Joist	10-1/2" O.C.	Joist	Long Edge	835	278
	2 x 31-1/2 x 96"	Steel	96"	218 Ts/3-1/4" 14-Gauge/2"w	2/Joist/Panel	12" O.C. sides + ends	Joist	Long Edge	1530	509
Tile T & G	2 x 31-1/2 x 96"	Steel	96"	000-5-14-2+S-25/2"w	32" O.C.+2/Joist	S-25@16" + 3/End	T&G + Per	Long Edge	696	231

¹ Values over wood joists are conservative compared to values over steel.

² Adhesive is to meet the requirements of AFG-01. A 3/8" bead of adhesive is to be used. Approximately 50 linear feet of adhesive per quart tube. Specific adhesive used on test assemblies was Miracle® SFA-66.

³ Spans achieved by bulb tee, not Tectum® tile.

Type	Panel Size D x W x L	Joist	Span ¹	Fasteners	Field Spacing	Perimeter	Adhesive ²	Grout	ULT/LF	DSN/LF
Tectum® III & IIIP										
Plank	3-1/2 x 47 x 120"	Wood	60"	6" 14-Gauge Sip Scr	3/Joist/Panel	12" O.C. sides + ends	T&G + Joist	None	1093	363
	3-1/2 x 47 x 144"	Wood	72"	6" 14-Gauge Sip Scr	3/Joist/Panel	12" O.C. sides + ends	T&G + Joist	None	1068	355
	5 x 47 x 144"	Wood	72"	6" 14-Gauge Sip Scr	3/Joist/Panel	12" O.C. sides + ends	T&G + Joist	None	964	320
Plank/ Overlay	5 x 47 x 144"	Wood	72"	6" 14-Gauge Sip Scr/1-1/2"w	6/Joist/Panel	6" O.C. sides + ends	T&G + Joist	None	2363	786
	7/16 x 48 x 144"	OSB	-	2" x 16-Gauge Staples	8"@ 24" Centers	4" O.C. sides + ends	Per & 24" O.C.	None	2363	786
Tile	3-1/2 x 47-1/2 x 96"	Steel	96"	000-3-14 3-1/2"+14GA/1-1/2"w	3/Joist/Panel	12" O.C. sides + ends	Joist	Long Edge	939	312

¹ Values over wood joists are conservative compared to values over steel.

² Adhesive is to meet the requirements of AFG-01. A 3/8" bead of adhesive is to be used. Approximately 50 linear feet of adhesive per quart tube. Specific adhesive used on test assemblies was Miracle SFA-66.

Type ¹	Panel Size D x W x L	Joist	Span ²	Fasteners	Field Spacing ³	Perimeter	Adhesive ⁴	Grout	ULT/LF	DSN/LF
Tectum® IIIV										
Plank	5 x 47 x 144"	Wood	72"	7" 14-Gauge Sip Scr/1-1/2"w	4/Joist/Panel	12" O.C. sides + ends	T&G + Joist	None	964	320
Plank/ Overlay	5 x 47 x 96"	Wood	72"	7" 14-Gauge Sip Scr/1-1/2"w	6/Joist/Panel	6" O.C. sides + ends	T&G + Joist	None	-	-
Overlay	7/16 x 48 x 144"	OSB	-	2" x 16-Gauge Staples	8" @ 24" Centers	4" O.C. sides + ends	Per & 24" O.C.	None	2363	786

NOTE: See Technical Bulletin T-77 for more information.

¹ Tectum E and III Roof Deck panels produce equivalent results.

² Values over wood joists are conservative when supports are steel.

³ All panels were installed with staggered ends except Tectum I tile with 168 bulb tees and Tectum III tile on truss tees.

⁴ Adhesive is to meet the requirements of AFG-01. A 3/8" bead of adhesive is to be used. Approximately 38 linear feet of adhesive per quart tube. Specific adhesive used on test assemblies was Miracle SFA-66.

Type	Panel Size D x W x L	Joist	Span ¹	Fasteners	Field Spacing	Perimeter	Adhesive ²	Grout	ULT/LF	DSN/LF
Tectum® E & E-N										
Plank	4 x 47 x 144"	Wood	72"	6" 14-Gauge Sip Scr	3/Joist/Panel	12" O.C. sides + ends	T&G + Joist	None	1042	346
	5 x 47 x 168"	Wood	84"	6" 14-Gauge Sip Scr	3/Joist/Panel	12" O.C. sides + ends	T&G + Joist	None	1012	336
	5 x 48 x 96"	Wood	96"	6" 14-Gauge Sip Scr	4/Joist/Panel	12" O.C. sides + ends	T&G + Joist	None	604	201
Plank/ Overlay	5 x 47 x 96"	Wood	96"	6" 14-Gauge Sip Scr	4/Joist/Panel	8" O.C. sides + ends	T&G + Joist	None	1315	437
	7/16 x 48 x 96"	OSB	-	2" x 16-Gauge Staples	8"@24" Centers	4" O.C. sides + ends	Per & 24" O.C.	None	1315	437

¹ Values over wood joists are conservative compared to values over steel.

² Adhesive is to meet the requirements of AFG-01. A 3/8" bead of adhesive is to be used. Approximately 50 linear feet of adhesive per quart tube. Specific adhesive used on test assemblies was Miracle SFA-66.

Type	Panel Size D x W x L	Joist	Span ¹	Fasteners	Field Spacing	Perimeter	Adhesive ²	Grout	ULT/LF	DSN/LF
Tectum® V										
Plank	4 x 47 x 144"	Wood	72"	6" 14-Gauge Sip Scr	3/Joist/Panel	12" O.C. sides + ends	T&G + Joist	None	1042	346
	5 x 47 x 168"	Wood	84"	6" 14-Gauge Sip Scr	3/Joist/Panel	12" O.C. sides + ends	T&G + Joist	None	1012	336
	5 x 48 x 96"	Wood	96"	6" 14-Gauge Sip Scr	4/Joist/Panel	12" O.C. sides + ends	T&G + Joist	None	604	201
Plank/ Overlay	5 x 47 x 96"	Wood	96"	6" 14-Gauge Sip Scr	4/Joist/Panel	8" O.C. sides + ends	T&G + Joist	None	1315	437
	7/16 x 48 x 96"	OSB	-	2" x 16-Gauge Staples	8"@24" Centers	4" O.C. sides + ends	Per & 24" O.C.	None	1315	437

¹ Values over wood joists are conservative compared to values over steel.

² Adhesive is to meet the requirements of AFG-01. A 3/8" bead of adhesive is to be used. Approximately 38 linear feet of adhesive per quart tube. Specific adhesive used on test assemblies was MasterWeld® 948. Miracle SFA-66 adhesive cannot be used with Tectum V.

Span	Plank Width	Fasteners Per Frame Intersect	Uplift Resistance ¹ (PSF)	Products	Span	Plank Width	Fasteners Per Frame Intersect	Uplift Resistance ¹ (PSF)	Products
36"	31"	2	150	I, LS	60"	47"	2	60	NS, E, III
36"	47"	2	100	I, LS, NS, E, III	60"	47"	3	90	NS, E, III
36"	47"	3	150	I, LS, NS, E, III	60"	47"	4	165	IIIW
36"	47"	4	321	IIIW	72"	31"	2	77	LS
42"	31"	2	133	I, LS	72"	31"	3	116	LS
42"	47"	2	89	I, LS, NS, E, III	72"	47"	2	50	NS, E, III
42"	47"	3	133	I, LS, NS, E, III	72"	47"	3	75	NS, E, III
42"	47"	4	275	IIIW	72"	47"	4	100	NS, E, III
48"	31"	2	117	I, LS	72"	47"	4	160	IIIW
48"	47"	2	77	I, LS, NS, E, III	96" ²	47"	2	50	E, III
48"	47"	3	116	I, LS, NS, E, III	96" ²	47"	3	75	E, III
48"	47"	4	241	IIIW	96" ²	47"	4	100	E, III
60"	31"	2	92	LS	144" ²	47"	7	94	V
60"	31"	3	138	LS					

NOTE: In this table, all listings for Tectum® E include both Tectum E and Tectum® E-N, and all listings for Tectum® III include Tectum III and Tectum® III-P.

¹ A safety factor of 2 has been used to determine uplift resistance. Screws will be a minimum of 2" longer than panel thickness. 1-1/2" diameter washer must be used. Panels must have a double span condition.

² Single Span

ROOF DECK TILE SYSTEMS LOAD CHARACTERISTICS – PSF

Tile Thickness	Weight (PSF)	Product(s)	Spacing of Bulb Tees ¹			
			24"	32"	48"	Span
1-1/2"	2.4	I	50	–	–	²
2"	3.5	I	90	50	–	²
2-1/2"	4.5	I, NS	140	80	–	²
3"	5.3	I, NS	150	100	50	²
3-1/2"	4.4	III, E, E-N, NS	150	–	70	²
4"	4.6	III, E, E-N, NS	150	–	100	²
5"	5.0+ up	III, E, E-N	150	–	120	²

NOTE: Spans up to 12' as determined by size of bulb tee.

¹ Special widths available to fit existing bulb tee spacings.

² Spans must be determined from subpurlin manufacturer's design catalog. The limiting design load is the smaller span capacity of the design loads for either the Tectum panel or the bulb tee. (See subpurlins spacing table to the right).

SUBPURLINS SPACING¹

Nominal Tile Width	Actual Tile Width	Spacing of Bulb Tees ²					
		112 ³	158 ³	168 ³	178 ³	218 ³	228 ³
24"	23-1/2"	24"	24"	24"	24"	24"	24-3/4"
32"	31-1/2"	31-3/4"	31-3/4"	31-3/4"	32"	32"	32-4/4"
48"	47-1/2"	47-3/4"	47-3/4"	47-3/4"	48"	48"	48"

Available in Tectum® I, 3" only or Tectum III and Tectum E in any thickness.

¹ See manufacturers' literature for additional selection data on bulb tees.

² Only 218 bulb tees are currently distributed. Contact WestPro Construction Solutions, Kansas City, KS, 816-561-7667.

³ Special order, schedule may vary.

TECHNICAL SUPPORT DATA, TOTAL SAFE UNIFORM LOAD – PSF

Style of Bulb Tees ¹	Weight	MOI ² IN	Height	Spacing of Bulb Tees ³															
				60"	66"	72"	78"	84"	90"	96"	102"	108"	114"	120"	126"	132"	138"	144"	
158 ⁴	1.68	0.017	1-5/8"	92	76	64	54	47											
168 ⁴	1.87	0.291	2"		109	91	78	67	58	51									
178 ⁴	2.15	0.353	2"			119	101	87	76	66	59	52							
218	3.19	0.598	2-1/8"					119	103	91	80	72	64	58	52	48			
228 ⁴	3.87	0.868	2-5/16"								129	114	102	91	82	74	68	64	57

¹ Only 218 bulb tees are currently distributed. Contact WestPro Construction Solutions, Kansas City, KS, 816-561-7667. The designer/specifier is urged to check theoretical deflection of any section, under the loads and support conditions which are expected to be encountered.

² Moment of Inertia based on tees acting alone.

³ Spans are based on three-span condition, 32" nominal spacing. For 24" nominal spacing, multiply total safe uniform load by a factor of 1.32, for 48" nominal multiply by .67.

For two-span condition, multiply total safe uniform load by .88, for single-span condition multiply by .64.

⁴ Historical information. Not available for new construction.



**PRODUCT
SELECTOR**

**LOW-SLOPE APPLICATIONS
TECTUM® I**

**SLOPED APPLICATIONS
TECTUM® COMPOSITES**

PRODUCT SELECTOR	LOW-SLOPE APPLICATIONS TECTUM® I				SLOPED APPLICATIONS TECTUM® COMPOSITES				
	Plank	Tile	LS	w/LWIC	NS	III & III P	III W	E & E-N	V
Spans									
Up to 48"	•		•	•	•	•	•	•	•
Up to 72"			•	•	•	•	•	•	•
Up to 96"						•		•	•
Up to 120"		• ¹ (bulb tee)							•
Up to 144"									•
Diaphragm/Shear									
Up to 312 dsn/lf	•		•	•		•	•	•	•
Up to 389 dsn/lf	•		•	•		•	•	•	•
Up to 450 dsn/lf	•		•	•		•	•	•	
Up to 542 dsn/lf			•	•		•	•	•	
Up to 786 dsn/lf						•	•	•	
Acoustics (NRCs)									
Up to 0.60	•	•	•	•	•	•	•	•	•
Up to 0.70	•	•	•	•	•			•	
Up to 0.80	•	•	•	•	•			•	
R-Value									
Up to 6	•	•	•	•	•	•	•	•	•
Up to 32						•	•	•	•
Up to 40						•	•	•	
Up to 44						•	•		
Available Surface									
				• ²	•	•	•	•	•

¹ Spans achieved by bulb tee, not Tectum tile.

² Tectum LWIC requires special fasteners for roofing felt attachment.

Roof Deck SELECTION CRITERIA

Light reflectance for a natural panel is up to 0.60.

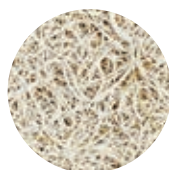

Natural

Choosing the right Tectum® Roof Deck solution is easy – use the product selection guide above to help you achieve the appropriate acoustical, structural, thermal, and aesthetic properties to meet your unique building design needs. Contact your Tectum Representative or our TechLine team for more information.



TECTUM® I ROOF DECK PANELS

Tectum® I Roof Deck system is typically used in low-slope applications and consists of standard Tectum panels in either plank (tongue-and-groove with a steel channel) or tile (grouted in place) configurations. With an NRC of up to 0.80, Tectum I is an ideal noise reduction solution for large, high-traffic spaces.

TECTUM® I Roof Deck Panels



▲ Tectum I Roof Deck

THERMAL ATTRIBUTES

Tectum I Roof Deck is compatible with virtually all roofing materials, and provides a thermal barrier for field-applied foam plastics. Underside exposed joints have attractive beveled edges. Long Span (LS) Plank panels require field-applied steel channels.

TECTUM I THERMAL PERFORMANCE

Panel Thickness	R-Value	Weight PSF
2"	3.68	3.7
2-1/2"	4.56	4.7
3"	6.43	6.2

TECTUM® I ROOF DECK PLANK & LONG SPAN PLANK

Tectum Roof Plank with T&G edges are available as Tectum I or as the substrate for all Tectum Roof Deck composite systems.

Tectum I Long Span Plank is available only as a Tectum I panel, using a 16-gauge galvanized steel channel for increased spans.

Tectum I Plank products are typically used in low-slope applications.

VISUAL SELECTION

Edge Detail	Thickness	Width	Length
T&G Sides w/ Square Ends	2", 2-1/2", 3"	23"	48" up to 144"
LS 16-Gauge Galvanized Steel Channel	2", 2-1/2", 3"	31"	48" up to 144"

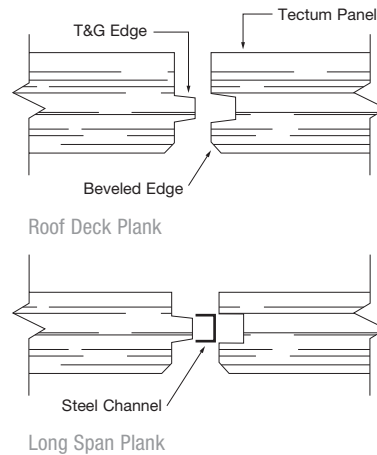



LOW-SLOPE APPLICATIONS

TECTUM® TILE

All Tectum Roof Deck products (including composite systems) are available in a tile configuration. In a tile configuration, a Tectum panel is used to span between steel bulb tees.

The rabbeted edges of Tectum Roof Deck Tile rest on steel tee flanges. Spaces between tile and tees are filled with Tectum Grout for excellent anchorage and wind uplift resistance. Custom lengths allow roof design with no exposed end joints.

VISUAL SELECTION

Edge Detail	Thickness	Width	Length
Rabbeted Sides w/Square Ends	2", 2-1/2", 3"	23-1/2" or 31-1/2"	48" up to 144"
	2-1/2", 3"	47-1/2"	48" up to 144"
Rabbeted Sides w/T&G Ends	2", 2-1/2", 3"	23-1/2" or 31-1/2"	48" up to 96"
	2-1/2", 3"	47-1/2"	48" up to 144"

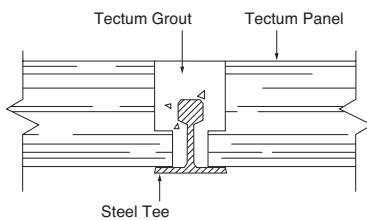

Roof Deck Tile on steel tees

TECTUM® I TILE OR PLANK WITH LIGHTWEIGHT INSULATING CONCRETE

Tectum Roof Deck Lightweight Insulating Concrete (LWIC) System uses Tectum I Plank or Tectum I Tile to provide a unique structural substrate for an LWIC topping. This system can be used over steel or wood structural systems.

The porous nature of Tectum products allows the LWIC to dry from the underside of the slurry. The result is a structural, acoustical deck with permanent insulation. The deck can be re-roofed without costly replacement and disposal of the existing insulation.

This roof deck system is proven, long-lasting, and economical for flat and low-slope roof decks. It is an ideal solution in areas where higher shear values are required.

STRUCTURE OF TECTUM ROOF DECK WITH LWIC

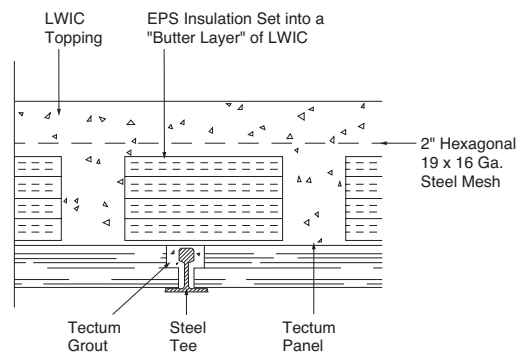

Note: Slope may be introduced to an otherwise flat roof deck with the use of tapered EPS and LWIC.

▼ Tectum I Plank LWIC Installation





TECTUM[®] COMPOSITE ROOF DECK PANELS

Tectum[®] Composite Roof Deck panels are typically used in sloped applications where acoustics, insulation, nailable surface, and structural integrity are all prioritized.

SLOPED APPLICATIONS

STRUCTURALLY SOUND

Tectum® Composite Roof Deck panels are topped with a slip-resistant 7/16" Oriented Strand Board (OSB). The components of Tectum Composite Roof Deck panels are bonded using code-listed structural adhesives.

OSB SHEATHING¹

Property	Result
Internal Bond	40 p.s.i.
Average Roofing Nail Withdrawal	50 lbs.
Average Roofing Staple Withdrawal	137 lbs.
Average Screw Withdrawal	355 lbs.
Average Roofing Nail Withdrawal	0.20%

¹ Structural Board Association Note: OSB meets the requirements of PS2-04 performance standard for wood-based structural use panels.

TECTUM® E-N

The Tectum E-N Roof Deck panel is a composite of a 1-1/2" or thicker Tectum substrate, Neopor® GPS (Graphite-enhanced polystyrene) insulation and 7/16" OSB sheathing with a slip-resistant surface. Components are bonded with code-listed structural adhesives. The Neopor GPS core exceeds the requirements of ASTM C-578 Type I and bears the UL® classification mark.

TECTUM E-N THERMAL PERFORMANCE

Tectum Panel Thickness	Insulating Foam Thickness	Total ¹ Thickness	R-Value ²	Weight PSF
1-1/2"	3/4"	2-3/4"	7.96	3.6
	1-1/2"	3-1/2"	11.56	3.8
	2"	4"	13.96	3.9
	3"	5"	18.76	4.7
	4"	6"	23.56	4.8
	5-1/4"	7-1/4"	29.56	5.2
	6-1/2"	8-1/2"	35.56	5.4
	7"	9"	37.96	5.6
	8"	10"	43.76	6.0

¹ Total thickness includes 7/16" OSB nailable top surface.

² R-Values include air films and built-up roofing.

GPS INSULATION

Property	Test	Result
Nominal Density	—	3.7
Thermal Resistance (R-Value ¹) Per Inch of thickness	C177/C518	4.70 @ 40° F 4.30 @ 75° F

¹ Typical tested R-values based on data from BASF Corporation and Huntsman Corporation ICCES ESR-2784.

TECTUM® E

Tectum E Roof Deck panel is a composite of 1-1/2" or thicker Tectum® I substrate, Expanded Polystyrene (EPS) insulation and 7/16" OSB. The EPS core exceeds the requirements of ASTM C-578 Type I, and bears the UL classification mark.

When a nailable surface is the primary reason for specifying a composite panel, Tectum E is also available as Tectum® NS (Nailable Surface) with minimal insulating value.

With an NRC of up to 0.80, Tectum E provides significant noise reduction in large spaces including auditoriums, multi-use facilities, and theaters.

TECTUM E THERMAL PERFORMANCE

Tectum Panel Thickness	Insulating Foam Thickness	Total ¹ Thickness	R-Value ²	Weight PSF
1-1/2"	3/4"	2-3/4"	7.24	3.6
	1-1/2"	3-1/2"	10.13	3.8
	2"	4"	12.06	3.9
	3"	5"	15.91	4.7
	4"	6"	19.76	4.8
	5-1/4"	7-1/4"	24.57	5.2
	6-1/2"	8-1/2"	29.38	5.4
	7"	9"	31.31	5.6
	8"	10"	35.16	6.0

¹ Total thickness includes 7/16" OSB nailable top surface.

² R-Values include air films and built-up roofing.

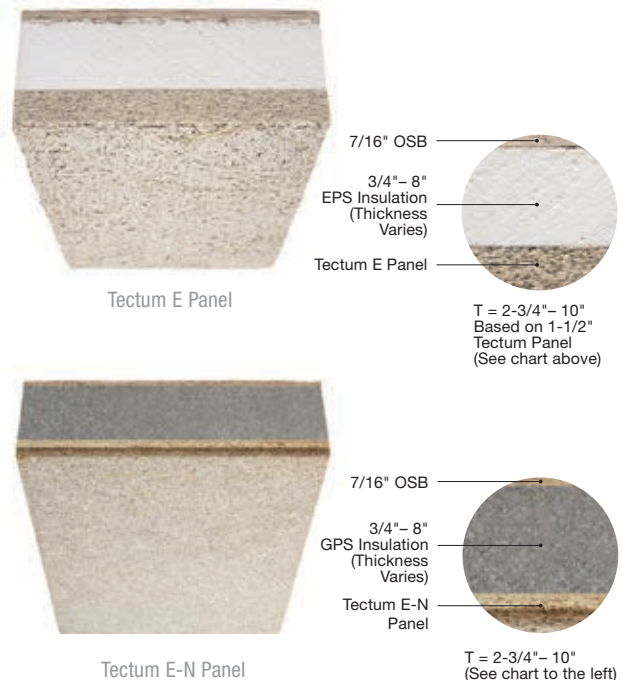

TECTUM® Composite Roof Deck Panels

TECTUM® III, IIP, & IIW

The Tectum III, IIP, and IIW Roof Deck panels are a composite of a 1-1/2" or thicker Tectum® substrate, Styrofoam™ Brand XPS Insulation 1-1/2" to 8" thick and 7/16" OSB sheathing for Tectum III and Tectum IIP. Tectum IIW has 19/32" plywood sheathing instead of OSB. All have a slip-resistant surface. Components are bonded with code-listed structural adhesives. Tectum III panels are typically used in sloped applications where noise reduction, insulation, and a nailable surface are required.

All three panels have an NRC of up to 0.60.

TECTUM III, IIP, & IIW THERMAL PERFORMANCE

Tectum Substrate	Insulating Foam Thickness	Total ¹ Thickness	R-Value ²	Weight PSF
1-1/2"	1-1/2"	3-1/2"	11.86	4.0
	2"	4"	14.36	4.1
	3"	5"	19.36	4.7
	4"	6"	24.36	4.8
	5"	7"	29.36	5.0
	6"	8"	34.36	5.4
	7"	9"	39.36	5.8
	8"	10"	44.36	6.2

¹ Total thickness includes 7/16" OSB or plywood nailable top surface. High humidity applications are not available in total thicknesses of less than 6".

² R-Values include air films and built-up roofing.



TECTUM IIP

The Tectum IIP Roof Deck has an edge detail specifically designed for use over high-humidity applications such as swimming pools, ice arenas, and some net-zero buildings. Factory-grooved panels and Styrofoam spline, when properly sealed with urethane adhesive, provide for a continuous vapor retarder from panel to panel in all directions. The result is a Tectum panel that meets the special needs of high-humidity environments while providing the acoustic performance expected from any Tectum product.

TEST RESULTS FOR STYROFOAM INSULATION

Property	Test	Result
Water Vapor Permeability ¹	E96-80	0.6
Compressive Strength	D161-04a	40 lb./sq. in. Min. 20 lb./sq. in.
Water Absorption	D2842-06	1% by volume
Linear Coef. of Thermal Expansion (in./in. °F)	—	3.5 x 105
Thermal Resistance	—	R=5.0/in.

¹ Typical tested R-Values based on data from BASF Corporation and Huntsman Corporation ICCES ESR-2784.

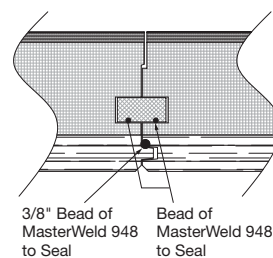

Tectum IIP End Joint

SLOPED APPLICATIONS

TECTUM® IIIW

The Tectum® IIIW Roof Deck is ideal for high wind installations, uplift resistant to 321 sq ft. The three-in-one Composite Roof Deck Panels with plywood sheathing provide acoustics, insulation, and a nailable surface that accepts a wide variety of roofing materials.

TECTUM IIIW DIAPHRAGM DESIGN DATA Call for assistance when designing and detailing Tectum® Roof Deck Systems

Type ¹	Panel Size D x W x L	Joist	Span ²	Fasteners	Field Spacing ³	Perimeter	Adhesive ⁴	Grout	ULT/LF	DSN/LF
Tectum® IIIW										
Plank	5 x 47 x 144"	Wood	72"	7" 14-Gauge Sip Scr/1-1/2"w	4/Joist/Panel	12" O.C. sides + ends	T&G + Joist	None	964	320
Plank/ Overlay	5 x 47 x 96"	Wood	72"	7" 14-Gauge Sip Scr/1-1/2"w	6/Joist/Panel	6" O.C. sides + ends	T&G + Joist	None	-	-
	7/16 x 48 x 144"	OSB	-	2" x 16-Gauge Staples	8" @ 24" Centers	4" O.C. sides + ends	Per & 24" O.C.	None	2363	786

NOTE: See Technical Bulletin T-77 for more information.

¹ Tectum E and III Roof Deck panels produce equivalent results.

² Values over wood joists are conservative when supports are steel.

³ All panels were installed with staggered ends except Tectum I tile with 168 bulb tees and Tectum III tile on truss tees.

⁴ Adhesive is to meet the requirements of AFG-01. A 3/8" bead of adhesive is to be used. Approximately 38 linear feet of adhesive per quart tube. Specific adhesive used on test assemblies was Miracle SFA – 66.

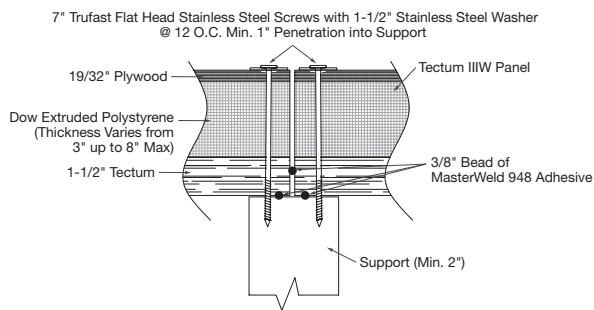

Tectum IIIW Over Support

▼ Tectum® IIIW Roof Deck in White Sun-N-Fun Lifestyle Wellness Center, Sarasota, FL



TECTUM® Composite Roof Deck Panels

SLOPED APPLICATIONS

TECTUM® V SPAN

The Tectum V Roof Deck panel is a composite of a 1-1/2" or thicker Tectum substrate, 1/2" Neopor® GPS (Graphite enhanced polystyrene) insulation, 7/16" OSB sheathing, 6" Neopor GPS insulation, and is topped by another 7/16" OSB sheathing with a slip-resistant surface. Components are bonded with code-listed structural adhesives. The Neopor GPS core exceeds the requirements of ASTM C-578 Type I, and bears the UL® classification mark. Tectum V provides an NRC of up to 0.60 together with a span of up to 12 feet.

TECTUM V THERMAL PERFORMANCE

Tectum Panel Thickness	Insulating Foam Thickness	Total ¹ Thickness	R-Value ²	Weight PSF
1-1/2"	6-1/2"	9"	36.11	6.0

¹ Total thickness includes two layers of 7/16" OSB.
² R-Values include air films and built-up roofing.

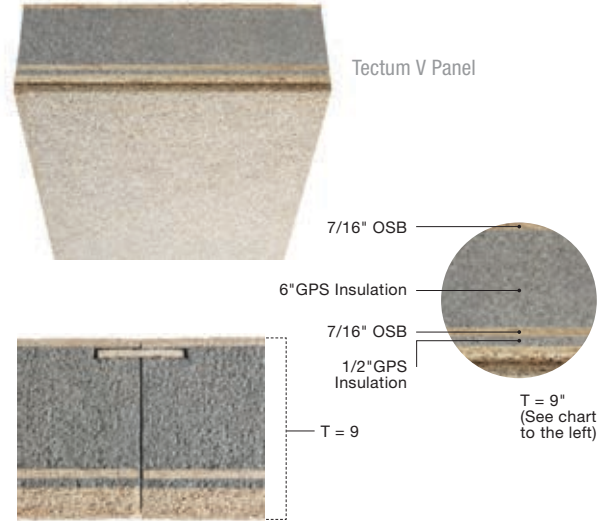

▼ Tectum III Roof Deck in Natural
 Judge B. Davies High School, Fargo, ND



CODE COMPLIANCE & CERTIFICATION

- International Code Council Evaluation Service ICC-ES Report ESR-1112
- New York City Board of Standards & Appeals Calendar No. L391-52-SM
- Underwriters' Laboratories – Canada
- Miami Dade NOA Approved (#18-0619.03)

UNDERWRITERS LABORATORIES, CLASS 90 WIND UPLIFT RESISTANCE

In addition to UL 580 Classification, Tectum® IIIW also has Miami Dade County NOA (Notice of Acceptance). The NOA covers the High Velocity Wind Zone areas of Broward (Fort Lauderdale) and counties with design wind speeds of 140 mph and 146 mph respectively. The NOA is the highest standard designed to protect structures from any wind-borne debris that would result from hurricane-force winds.

Design No. NM504 – Tectum® I Tile – Nominal 2" on bulb tees, not to exceed 7'-1".

Design No. NM511 – Tectum® Tile – Nominal 2" to 3". T&G on bulb tees, spans not to exceed 8'.

Design No. NM512 – Tectum Tile – with filler strips on bulb tees, spans not to exceed 7'-6".

Design NM517 – Tectum® III T&G plank on bar joist 48" O.C.

Design 474 & 475 – Tectum® E/III plank on steel 84".

Design 451 – Tectum E/III plank/tile on steel 96".

Underwriters' Laboratories – Canada

RATED ASSEMBLIES FIRE ENDURANCE TEST ASTM E 119-HOURLY RATED SYSTEMS

Tested in roof/ceiling assemblies. Tectum products are used in achieving the following:

2-HR U.L. Design No. P402 – Tectum® Plank 2" (50.8mm) thick on steel joists with metal lath and perlite plaster ceiling.

2-HR U.L. Design No. P403 – Tectum Plank 3" (76.2mm) thick on steel joists with metal lath and perlite plaster ceiling.

1 or 1-1/2 HR U.L. Design P253 – Tectum Plank 2-1/2" and 3" thick with listed acoustical ceiling.

1 HR U.L. Design P675 – Tectum® Formboard 2" thick with gypsum concrete and truss tee subpurlins.

1 HR U.L. Design P678 – Tectum Formboard 2" thick with vermiculite or perlite concrete on bulb or truss tee subpurlins.

LIGHT REFLECTION

Typical Range:

Natural – up to 0.60

PAINTING

Tectum panels can be field-painted up to six times with acrylic dry fall or flat latex paint. For details see roof deck installation instructions at armstrongbuildingsolutions.com

THERMAL BARRIER

Tectum panels 1-1/2" or thicker are a thermal barrier for foam plastic insulation. (see ICC-ES Report ESR-1112, Section 3.5)

SURFACE BURNING CHARACTERISTICS

3" Tectum® Roof Deck¹

- Flame Spread Index 5
- Flame Spread Index (30 min) 5
- Smoke-Developed Value 5

8" Tectum III Panels²

- Flame Spread Index 5
- Smoke-Developed Value 10

The flame spread did not progress more than 10'-6" during the 30-minute test.

¹ United States Testing Co. Inc. No. 09016

² Underwriters' Laboratories of Canada

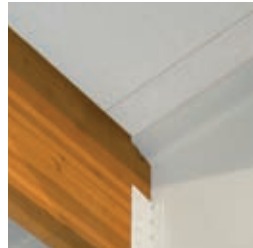

EXPANSION & VENTILATION

Tectum Roof Decks, when tested from 70°F (21°C) at 50% relative humidity to 90°F (32°C) at 90% relative humidity have maximum linear expansion of 0.2 of 1%.

Tectum Plank does not require expansion or control joints to compensate for temperature-induced movement. However, when designing and locating control joints, engineers should consider the linear expansion of Tectum Plank due to changes in relative humidity, as well as the recommendations of manufacturers of adjoining materials which may have potential for expansion/contraction due to temperature changes.

The ventilation recommendations of the current edition of the ASHRAE Handbook – Fundamentals should be followed. In particular, adequate ventilation should be provided to remove construction moisture. Where a Tectum Roof Deck is concealed by a suspended ceiling, venting must be provided. Ventilation may be mechanically induced by drawing some return air through the ceiling openings and across the plenum area into the return air duct. Ventilation may also be achieved by providing a sufficient number of ceiling grilles to promote uniform gravity air movement through the plenum area.

CODE COMPLIANCE

WARNING: All foam insulation should be adequately protected. Styrofoam™ Brand XPS Insulation and EPS insulation are combustible and may constitute fire hazards if improperly used or installed. Use only as directed by the specific instructions for these products. Styrofoam Brand and EPS insulation contain a flame-retardant additive to inhibit accidental ignition from small fire sources. During shipping, storage, installation, and use, this material should not be exposed to flame or other ignition sources.

TAKE THE NEXT STEP

1 877 276 7876

Customer Service Representatives

7:45 a.m. to 5:00 p.m. EST Monday through Friday

TechLine – Technical information, detail drawings, CAD design assistance, installation information, other technical services – 8:00 a.m. to 5:30 p.m. EST, Monday through Friday. FAX 1 800 572 8324 or email: techline@armstrongceilings.com

armstrongbuildingsolutions.com/tectum

Latest product news

Standard and custom product information

Online catalog

CAD, Revit®, SketchUp® files

Product literature and samples – express service or regular delivery

Declare® and Living Building Challenge® are registered trademarks of the International Living Future Institute®; WELL Building Standard™ is a trademark of the International WELL Building Institute; NEOPOR® is a registered trademark of BASF; UL® is a trademark of UL LLC; Miracle® Construction Adhesive is a registered trademark of ITW Polymers Sealants North America; MasterWeld® is a registered trademark of Master® Builders Solutions Construction Systems US, LLC; Styrofoam™ is a trademark of Dupont; Revit® is a registered trademark of Autodesk, Inc.; SketchUp® is a registered trademark of Trimble, Inc.; LEED® is a registered trademark of the U.S. Green Building Council®; FSC® is a registered trademark of FSC Forest Stewardship Council®, A.C., license code FSC-C007626; All other trademarks used herein are the property of AWI Licensing LLC and/or its affiliates.
© 2021 AWI Licensing LLC Printed in the United States of America

armstrongbuildingsolutions.com/tectum

On the cover: ▶
Tectum® E Roof Deck Panels in White
Middlebridge School, Narragansett, RI

Armstrong®
BUILDING SOLUTIONS