

Architectural Specifications

SPECIFICATIONS – BIRD JOLT 2002 ELECTRIC BIRD DETERRENT

PART 1 – GENERAL

1.1 SUMMARY

- A. Description of work: Work for this section includes, but is not limited to the following:
1. Electrified wire bird deterrent system.
 2. Control devices and associated wiring and connections for the work of this Section.

1.2 QUALITY ASSURANCE

- A. Single Source Responsibility: Furnish products from one manufacturer for the entire Project.
- B. Obtain all technical information from the manufacturer.
- C. Utilize labor or Bird-B-Gone Authorized Installers who are knowledgeable in Bird-B-Gone product installations.
- D. Installer shall visit the site to gather all information of existing site conditions.

1.3 SUBMITTALS

- A. Submit all descriptive information for the manufacturer including catalogs, installation instructions and other descriptive material.
- B. Provide Warranty on Material and Installation.
- C. Provide samples of each type of hardware, including proposed fastening methods.
- D. Provide statement by official indicating that they are a certified installation company.

1.4 SYSTEM REQUIREMENTS

- A. Electrical Requirements:
1. Provide wiring in accordance with applicable local codes and National Electric Code Standard.
 2. Test wiring system for insulation to ground.

1.5 PRODUCT HANDLING

- A. Protect Bird-B-Gone products from damage before, during and after the installation.

1.6 PROJECT CONDITIONS

- A. Coordination: Furnish samples of system so installation can be coordinated with existing conditions and within on-site tolerances.
- B. Visit site and field measure prior to fabrication and delivery of materials.

1. If field measurements cannot be taken, no additional compensation will be allowed on account of differences between actual measurements and dimensions on Drawings.
2. Verify conditions including offsets and other dimensions.

1.7 WARRANTY

- A. Product shall carry a minimum 5-year guarantee against U.V. breakdown.

PART 2 – PRODUCTS

2.1 ACCEPTABLE MANUFACTURER

- A. Manufacturer:
Bird-B-Gone, Inc.
 Bird Jolt 2002 – Electric Bird Abatement System
 23918 Skyline
 Mission Viejo, CA 92692
 Tel: 800-392-6915 or 949-472-3122
 Fax: 949-472-3116
 P.O.C.: Bruce Donoho

2.2 PRODUCT DESCRIPTION

- A. Model Designation: Bird Jolt 2002 – Electric Bird Abatement Systems
1. BJIECHI 10: Bird Jolt 100 v. Electrical Charger. Input Voltage: 110-120 VAC, 60 Hz, .035 amp, 10W. Output Voltage: 800 V (+/-) 100V, 10 mA (+/-) 2 mA, intermit AC output Plug in Charger U.L. Approved.
 2. BJISCH: Bird Jolt Solar Charger. Input Voltage: 4B, .02 amp, .08W. Output Voltage: 7.5 KV (+/-) 2 KV, 3 amp (+/-) 1 amp (Intermittent DC Output)

2.3 MATERIALS

- A. System Components
1. Clear Polycarbonate (Lexan®) Insulators with U.V. Inhibitors
 2. Anodized Aluminum Connector Rods (4 ft. sections)
 3. Insulated Ground Wire: 18 NTW.
 4. Insulated Connectors to attach ground wire to rods.
 5. Crimping Tool.
 6. Controllers (BJISCH or BJIECHI 10). See 2.2 for Electrical characteristics.
 - a. Housed in NEMA Type 4 or 3 weatherproof enclosure.

2.4 MOUNTING SYSTEMS

- A. Metal: Provide self-drilling stainless steel screws with resilient washers for fastening.
- B. Brick, Concrete and other surfaces: Provide anchor plates and adhesive for fastening to structure.
- C. Other: Provide anchors, inserts, warning decals and other miscellaneous accessories as required for complete installation.

PART 3 – EXECUTION

3.1 EXAMINATION

- A. Examine the installation area and note any detrimental or hazardous work conditions. Notify contracting officer or inspector of the detrimental work conditions.
- B. Do not proceed with the installation until conditions are corrected.

3.2 SURFACE PREPARATION

- A. Surface should be thoroughly cleaned and free of bird droppings, nesting materials, rust, peeling paint or other debris.
- B. Remove or repair articles that may damage Bird Jolt Electric Bird Abatement System including overhanging foliage, brush and loose parts on the structure.

3.3 INSTALLATION

- A. Install Bird Jolt 2002 Electric Bird Abatement System.
1. Install with appropriate anchors or fasteners for each substrate.
 2. Space materials in accordance with the manufacturer's recommendations.
 - a. Follow angles and contours closely.
 3. Install warning decals on windows where electrified wire is on ledge outside.
 4. For installations on roofs, coordinate with placement of ballast.

3.4 INSPECTION

- A. Upon completion of installation, test operation to demonstrate satisfactory operation and acceptability.
- B. Visually inspect Bird Jolt 2002 Electric Bird Abatement System for any signs of poor installation, including loose screws, fasteners or un-removed debris.
- C. Immediately correct and repair as necessary.

END OF SPECIFICATIONS

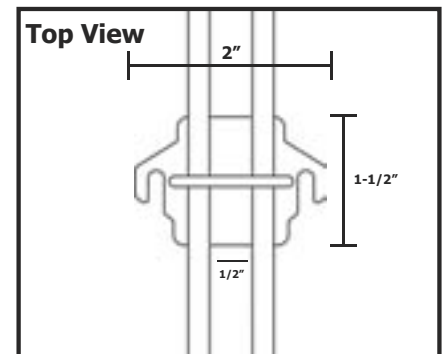
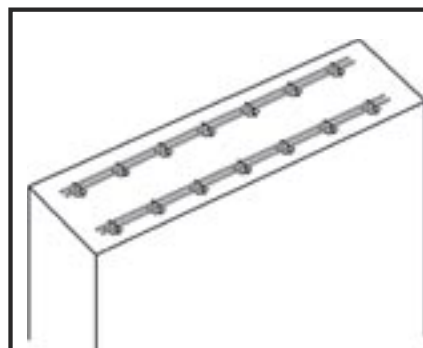
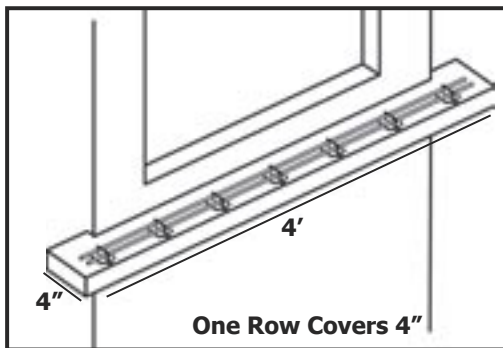

BIRD•B•GONE INC.
 For Customer Assistance Call
1-800-392-6915