

Regal[®] Flushometer

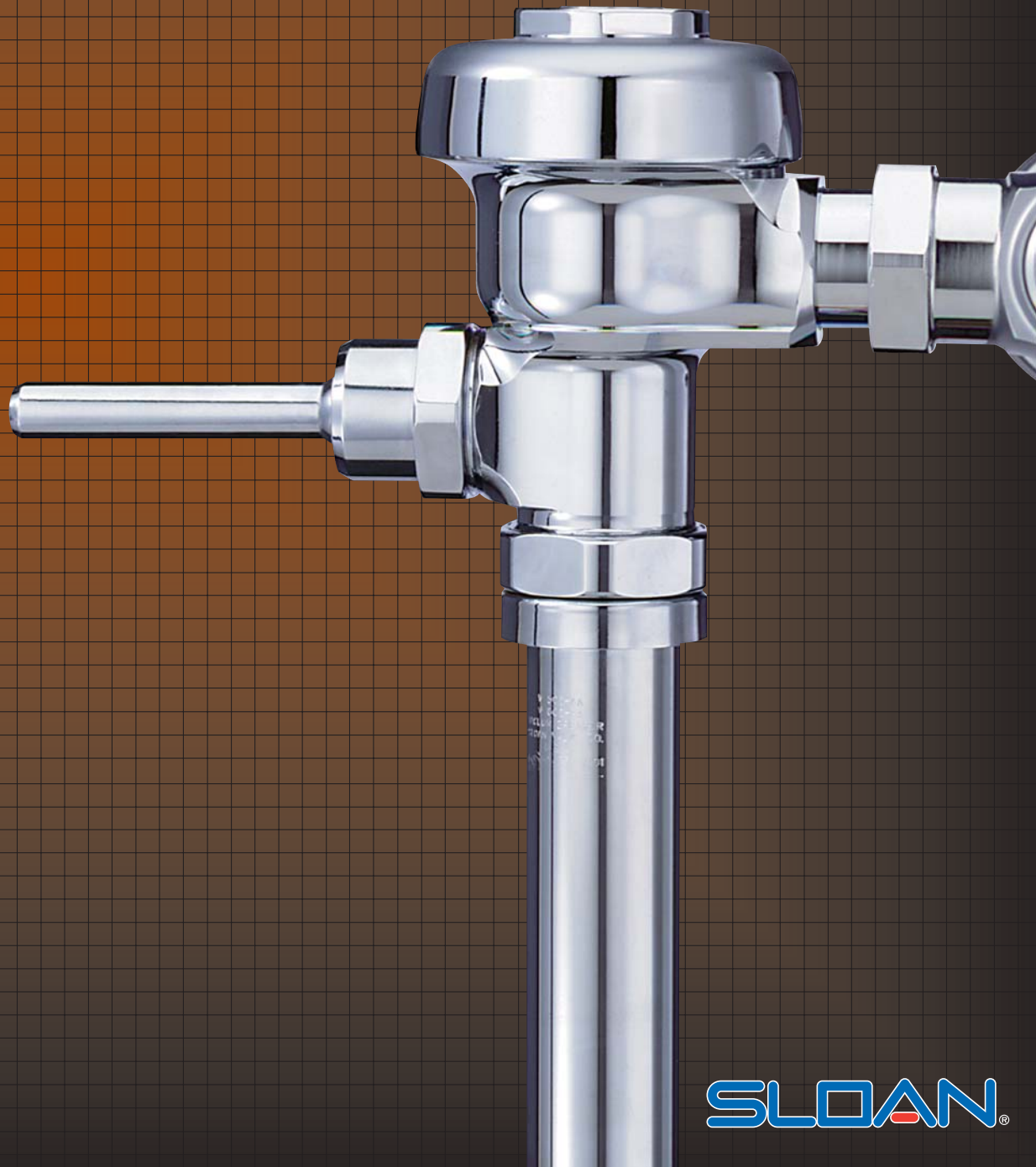

SLOAN[®]

Back to Bas Compromis

The **Sloan Regal**[®] Flushometer incorporates standards for Flushometer design, quality and performance that should be expected and required from any Flushometer installed in a typical commercial, institutional or industrial washroom. The components of the Regal valve reflect the proud design heritage of the Sloan family of Flushometers.



The Sloan REGAL is the result of an extensive testing program designed to manufacture a quality Flushometer at a competitive price. In addition, the Sloan name on a Flushometer is your guarantee of trouble-free performance over an extended service life.

Basics without Compromising Quality



The Regal® Flushometer incorporates those “**Back to Basic**” features that you have associated with Sloan Flushometers:

- Accurate, non-adjustable flush delivery
- High copper, low zinc semi-red cast brass alloy
- Oscillating, Non-Hold Open Handle
- Bak-Chek® Control Stop with vandal-resistant cap
- Easy Repair and Maintenance
- Guaranteed Performance - 3 Year limited warranty
- Made in USA

Best of all, Regal Flushometers are available at costs competitive with foreign sourced ‘copycat’ valves. Do your open spec clients/customers a favor and offer them a Regal Flushometer. It is their assurance of dependable Sloan performance and quality.

Upgrade to the Regal® XL

You can upgrade
your Regal to a
Regal XL Flushometer.
This includes:

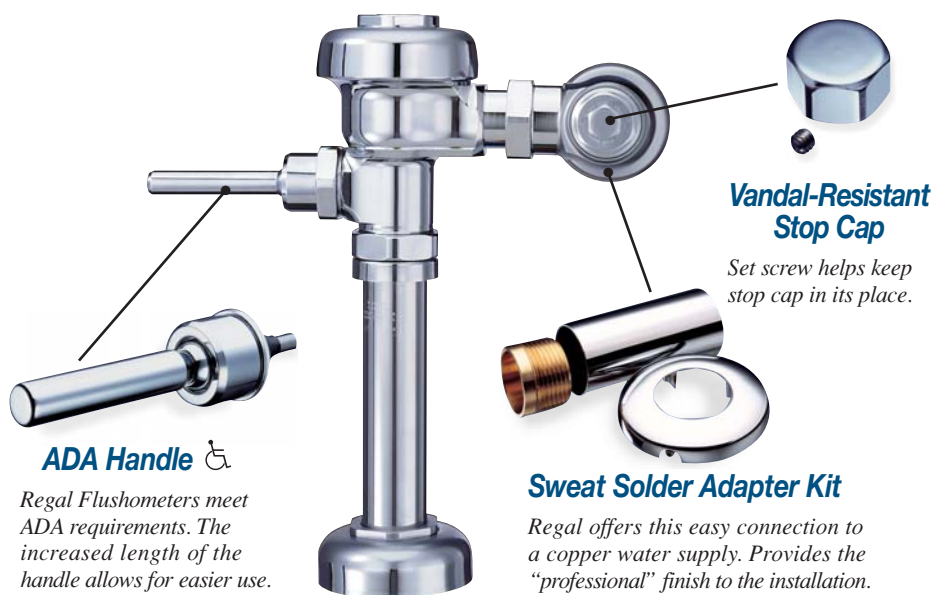

Sloan, the leader in quality plumbing solutions

Regal Flushometers are available in a wide variety of styles to meet your installation needs.

FIXTURE AND FLUSHING VOLUMES

Water Closet Flushometer

- 1.6 gpf (6.0 Lpf) - low consumption
- 3.5 gpf (13.2 Lpf) - water saver

URINAL FLUSHOMETERS

- 0.5 gpf (1.9 Lpf) - ultra low flush
- 1.0 gpf (3.8 Lpf) - low consumption
- 1.5 gpf (5.8 Lpf) - water saver

The Regal Flushometer is also available with a 3.5 gpf (13.2 Lpf) flush for older, blow-out urinals

SERVICE SINK FLUSHOMETERS

- 6.5 gpf (24.5 Lpf) Flush Delivery

ACCESSORIES

Regal Flushometers are available with a wide variety of accessories and variations. Please refer to the appropriate section in the Sloan catalog.

Sloan Valve Company
10500 Seymour Avenue
Franklin Park, IL 60131
Phone: 800-9-VALVE-9 (800-982-5839) ext. 5609
Fax: 800-447-8329
www.sloanvalve.com

Sloan offers 100 years of experience in the design, engineering and manufacturing of plumbing products. As a recognized leader in the industry, Sloan is dedicated to providing you with unsurpassed *Service* and *Quality*.

SERVICE From our worldwide distribution network, Sloan products are available when you need them. Sloan's Installation Engineering Department is on call to assist you whenever a question or problem arises with any Sloan product application.

QUALITY The foundation of Sloan's success is the *Quality* of its products. This *Quality* is integrated into all aspects of Sloan's operations. From design through production, Sloan's dedicated workforce is committed to a spirit of teamwork and cooperation. Your total satisfaction is our goal.

SLOAN PRODUCTS In addition to Regal Flushometers, Sloan manufactures a wide variety of plumbing products, including:

- | | |
|---|--|
| ■ Royal® Flushometers | ■ Optima® Flushometers and Faucets |
| ■ Gem® Flushometers | ■ Optima Plus® Flushometers and Faucets |
| ■ Dolphin® Flushometers | ■ Optima® Electronic Scrub sinks and Handwashing sinks |
| ■ Naval® Flushometers | ■ Optima® Hand Dryers |
| ■ Slimline® Bedpan Washing Systems with Bio-Gard® | |
| ■ Act-O-Matic® Shower Heads | |